

ZnNi0.15% (Technigalva[®] Light) Technical Datasheet

Uses

Pre-alloyed (lead free) Zinc-Nickel alloy suitable for hot dip galvanising of iron and steel products.

Chemical specification

Chemical specification	Guaranteed analysis	Tolerance
Ni	0.15%	± 0.03%
Pb	≤ 0.010%	
Cd	≤ 0.003%	
Fe	≤ 0.005%	
Sn	≤ 0.005%	
Cu	≤ 0.001%	
Al	≤ 0.005%	
Zn	balance	

Physical data

Physical property	Unit	Value
Density solid	kg/dm ³	7.14
liquid (@ 419 °C)	kg/dm ³	6.62
Melting point	°C	419
Superficial tension (@ 450 °C)	N/m	0.78
Melting enthalpy	kJ/kg	100
Thermal capacity solid	J/kg K	460
liquid	J/kg K	628

Available shapes/package

Shape/package	Nominal weight (in kg)	Dimensions (in mm)
Slab	25	470 x 235 x 40
Slab Bundle (40 slabs per bundle)	1000 ± 100	940 x 470 x 435
Colour marking: green		

ZnNi0.15% (Technigalva[®] Light) Technical Datasheet

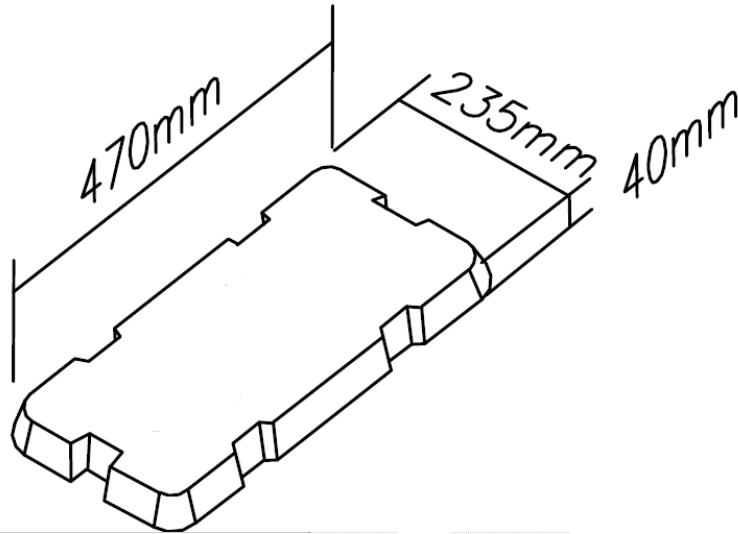
Slab**Nominal mass 25 kg**
Dimensions 470 x 235 x 40**Bundle****Nominal mass 1000 ± 50 kg**
Dimensions 940 x 470 x 435