

# Continuous Galvanizing Grade (ZnAl alloys) Technical Datasheet

## Uses

Pre-alloyed (lead free) Zinc-Aluminum alloys suitable for continuous galvanizing of iron and steel products.

## Chemical specification

Chemical specification*	Guaranteed analysis	Tolerance
Al	0.1 – 1.0%	± 0.05%
Pb	≤ 0.004%	
Cd	≤ 0.005%	
Fe	≤ 0.005%	
Sn	≤ 0.005%	
Cu	≤ 0.005%	
Zn	balance	

\* Extra impurity elements or control tolerance might be added based on commercial agreement

## Physical data

Physical property	Unit	Value
Density solid	kg/dm <sup>3</sup>	7.14
liquid (@ 419°C)	kg/dm <sup>3</sup>	6.62
Melting point	°C	419
Superficial tension (@ 450°C)	N/m	0.78
Melting enthalpy	kJ/kg	100
Thermal capacity solid	J/kg K	460
liquid	J/kg K	628

## Available shapes/package

Shape/package	Nominal weight (in kg)	Dimensions (in mm)
Australia Origin		
L block	1135 ± 45	1820 x 455 x 260
D block/ASTM Jumbo Ingot	1089 ± 45	1240 x 500 x 330

# Continuous Galvanizing Grade (ZnAl alloys) Technical Datasheet

L block (Jumbo), 2 holes  
Australia

Nominal mass 1135± 45kg  
Dimensions 1820 x 455 x 260

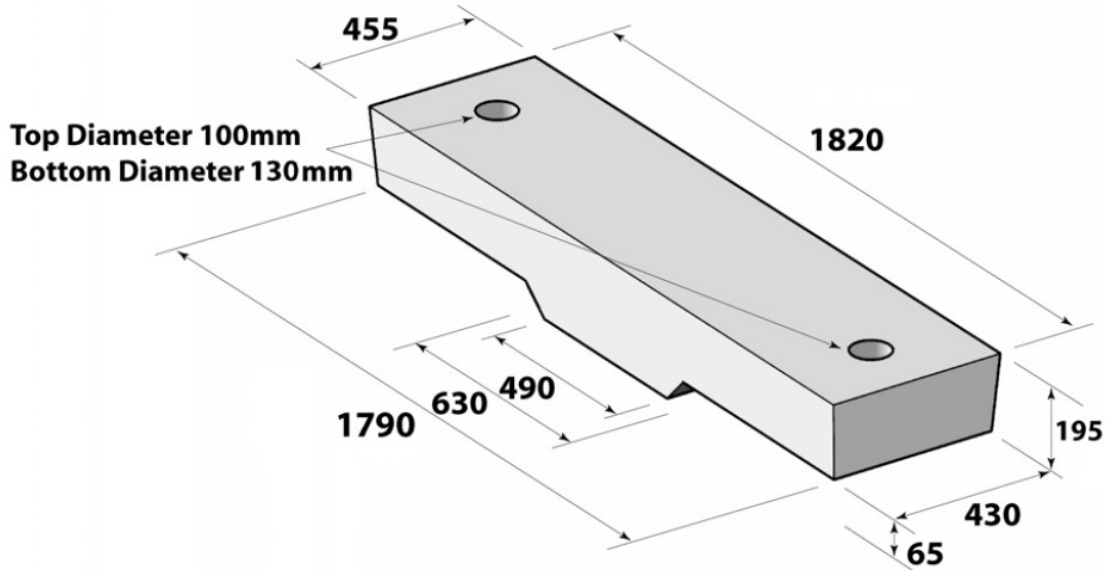

D block/ASTM Jumbo Ingot  
Australia

Nominal mass 1089 ± 45kg  
Dimensions 1240 x 500 x 330

