

Zinc Die Casting Alloys (EZDA)

Technical Datasheet

Uses

Zinc alloys are ideal for mass production of strong accurate components e.g. by hot chamber die casting process.

Characteristics

Chemical composition (AS1881) Guaranteed analysis (in %)	EZDA 3 ZL3/ZL0400 ZnAl4
Al Mg Cu Pb Fe Cd Sn Si Ni In Tl	3.9 - 4.2 0.04 - 0.05 ≤ 0.03 ≤ 0.003 ≤ 0.020 ≤ 0.002 ≤ 0.001 ≤ 0.02 ≤ 0.001 ≤ 0.0005 ≤ 0.001
Typical analysis (in %) (reference 2007)	EZDA 3 ZL3/ZL0400 ZnAl4
Al Mg Cu Pb Fe Cd Sn Si Ni In Tl	4.08 0.045 0.001 0.002 0.003 0.0005 0.0005 0.005 0.0003 0.0005 0.0003
Physical data	EZDA 3 ZL3/ZL0400 ZnAl4
Density (kg/dm ³ at 20 °C) Solidification range (°C) Shrinkage in % Linear thermal expansion (coefficient/°C) Electrical conductivity (%IACS)	6.6 381-387 4 - 5 27.4 x 10 ⁻⁶ 27

Standards complied with

Country/region	Standard	Zinc alloy designation
Australia USA Japan European Worldwide	AS 1881-1986 ASTM B240-07 JIS H2201-1999 EN1774-1998 ISO 301-2006	ZnAl4 Z33521 Zinc Alloy Type 2 ZnAl4 (ZL0400/ZL3) ZnAl4

Zinc Die Casting Alloys (EZDA)

Technical Datasheet

Package

Trademark	EZDA
Ingot weight Ingots per bundle Packing/weight	9.4 kg 112 strapped bundles of about 1050 kg

Slab

Nominal mass 9.4 kg
Dimensions 462 x 106 x 48

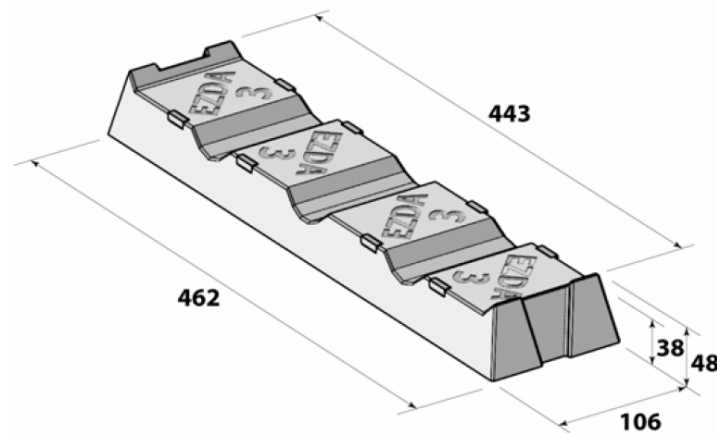

Slab bundle (112 slabs per bundle)

Nominal mass 1050 kg
Dimensions 930 x 460 x 570

